

ravvivamole a rotella con diamanti multipli ottaedrici
multipoint octahedral diamond dressing roller

codice <i>code</i>	n° diamanti <i>n° diamond</i>	carati <i>carats</i>	impieghi <i>applications</i>
RVST4 01.50	4	1,5	Ravvivatura mole per interni. Sgrossatura di mole tenere molto impastate. Raggiature manuale o meccanica. <i>Dressing internal wheels. Rouging out heavily "loaded" wheels. Manual or mechanical radiusing</i>
RVST4 02.00	4	2,0	
RVST4 03.00	4	3,0	
RVST6 01.50	6	1,5	
RVST6 02.00	6	2,0	
RVST6 03.00	6	3,0	
RVST8 01.50	8	1,5	
RVST8 02.00	8	2,0	
RVST8 03.00	8	3,0	

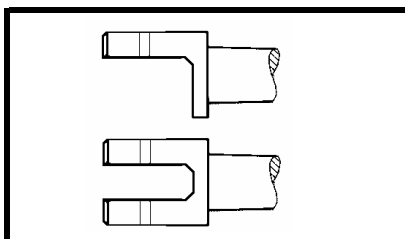

gambo su richiesta
shank on request

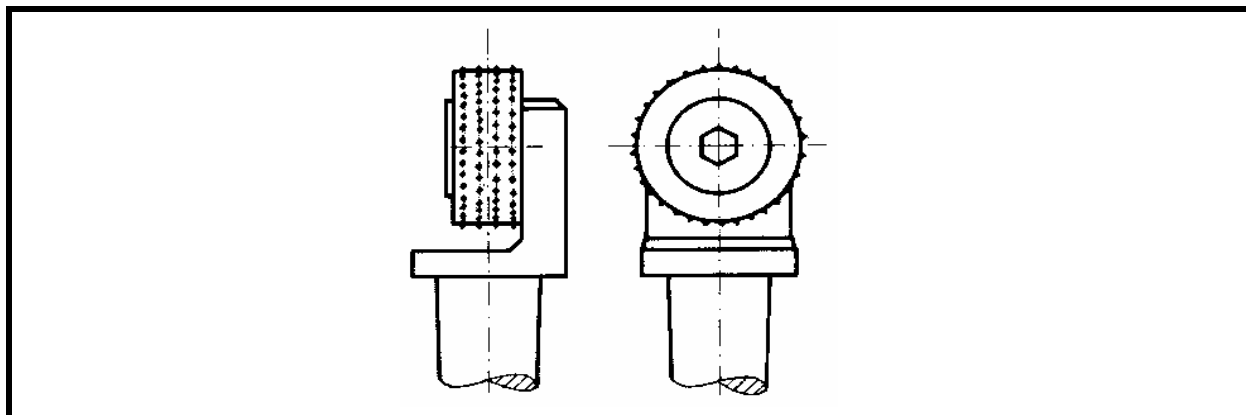

ravvivamole a rotella con diamanti multipli
multipoint diamond dressing roller

codice code	n° diamanti n° diamond	∅	carati carats	impieghi applications
RVMR.01.00D18X2	2 file di 16 pietre <i>2 line of 16 stones</i>	18	1,0	Ravvivatura piana. Ravvivatura di mole molto impastate. Sgrossatura di mole dure. Spianatura in genere per Centerless e per lavorazioni a tuffo <i>Flat wheel dressing. Dressing heavily "loaded" wheels. Roughing out hard bond wheels. Flat dressing Centerless or plung grinding wheels</i>
RVMR.02.00D18X4	4 file di 16 pietre <i>4 line of 16 stones</i>	18	2,0	
RVMR.02.50D18X4	4 file di 16 pietre <i>4 line of 16 stones</i>	18	2,5	
RVMR.03.00D18X4	4 file di 16 pietre <i>4 line of 16 stones</i>	18	3,0	
RVMR.04.00D18X4	4 file di 16 pietre <i>4 line of 16 stones</i>	18	4,0	
RVMR.05.00D21XA	5 file di 16 pietre <i>5 line of 16 stones</i>	21	5,0	
RVMR.05.00D21XB	5 file di 24 pietre <i>5 line of 24 stones</i>	21	5,0	

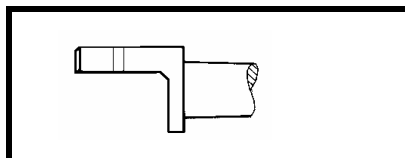

gambo su richiesta
shank on request

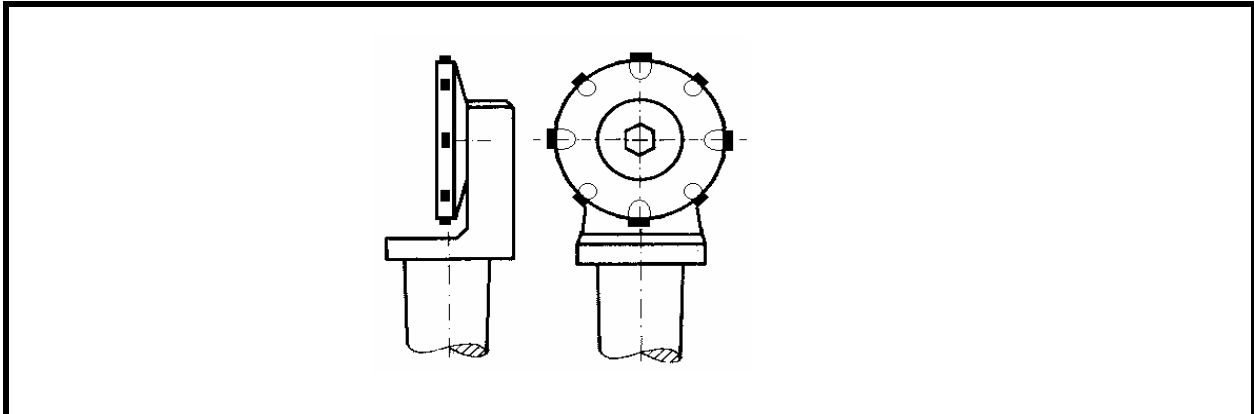

profilatore a rotella con diamanti multipli lamellari
multipoint lamellar diamond forming roller

codice <i>code</i>	n° diamanti <i>n° diamond</i>	carati <i>carats</i>	impieghi <i>applications</i>
RVLM 01.00	8	1,0	Profilatura mole per rettifica
RVLM 02.00	8	2,0	<i>Grinding wheels form</i>

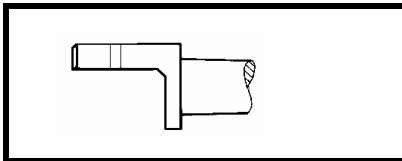

gambo su richiesta
shank on request